

INSTALLATION INSTRUCTIONS

SAFETY BABY CHANGING TABLE

READ THE INSTALLATION INSTRUCTIONS THOROUGHLY BEFORE COMMENCING INSTALLATION

The design of the safety baby changing table makes it easy to mount in even very small rooms. The changing table must be mounted onto a wall which is suited to carry the weight of the table as well as a baby - preferably a solid wall!

WHERE TO MOUNT THE BABY CHANGING TABLE

Determine the ideal place to mount the baby changing table. Keep in mind that the depth of the changing table is 625 mm in open position. The distance from the floor to the lower edge of the table mountings should be approx. 750 mm (see FIG. 1). Doorways, sinks etc. should of course also be taken into consideration when choosing where to mount the changing table.

IMPORTANT: Do **NOT** mount the table in a chlorine-containing environment!

MARKING AND DRILLING HOLES

To mount the changing table onto brick, gas concrete or the like, use 10 mm screws and matching universal plastic dowels – e.g. Fischer fixings type UX10.

When mounting the changing table onto a cavity wall of min. 16 mm (or 2 x 13 mm) plaster board, we recommend prior mounting of a reinforcement plate of stainless steel, plywood or the like, onto which the changing table is subsequently mounted. Attach reinforcement plate to the wall using a considerable number of special metal cavity fixings, Fischer art. no. 62315 or equivalent (art. no. 62328 for double plate). The changing table itself is also mounted with these screws and dowels – plus one metal washer per screw hole. For further details, please refer to the instructions of the dowel supplier.

In places where plaster walls have not yet been finished, we suggest mounting a 16 mm plywood board on the inside of the plaster wall, rendering the need for a reinforcement plate on the outside unnecessary.

Mark and drill holes as indicated on FIG. 1. The top holes for the table mountings should be drilled into solid brick - not into a joint.

IMPORTANT: Be sure to drill the holes for the mountings **exactly** vertically underneath each other, or the pneumatic shock absorbers inside the mountings may break!

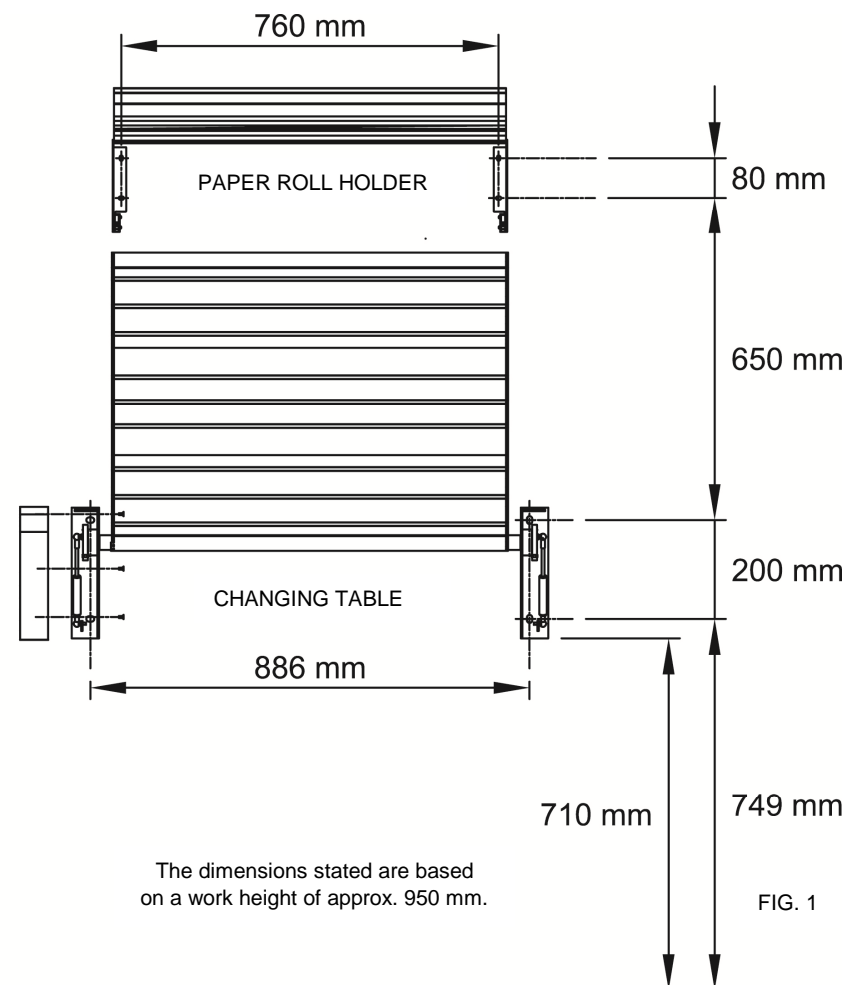

MOUNTING THE BABY CHANGING TABLE

- 1 Disassemble the cover plates of the table mountings by removing the 6 screws (3 on each) with a Torx screwdriver no. 20.
- 2 Mount the table onto the wall, making sure that it is completely level.
- 3 The changing table is factory pre-adjusted to easily close when given a slight push from open position.
- 4 Check that the changing table is mounted solidly onto the wall.
- 5 Check that the shock absorbers can pass freely when opening and closing the table.
- 6 Reassemble the cover plates onto the mountings.

MOUNTING PAPER HOLDER

The paper holder consists of the following parts:

1 holder (aluminium profile)
Left-side angle bracket with lock and lock arm
Right-side angle bracket
1 square keys

- 1 Mark and drill holes as indicated in FIG. 1.
- 2 Fix angle brackets onto the wall with 6 mm screws and plugs suited for the wall type onto which the paper holder is to be mounted.

Please take note:

- that the aluminium profile must be assembled in the angle brackets before the last bracket is fixed to the wall.
 - that the paper holder can only be closed, when the lock arm is in horizontal position.
 - that the square key – and thus the lock arm – can only be turned when the key is pressed into the actual lock cylinder.
- 3 Rest a paper roll inside the paper holder and tip the holder towards the wall, making the white locking devices click.
 - 4 Lock paper holder by turning the lock arm to vertical position.

INSTALLATION INSTRUCTIONS

DAN DRYER® SAFETY BABY CHANGING TABLE



DAN DRYER A/S

Alsikevej 8 • DK-8920 Randers NV • Tel.: +45 86 41 57 11 • Fax: +45 86 41 60 89